

Description

Coburn Straightaway sliding door system for doors up to 100kg per leaf



Technical Features

Function & Operation The Straightaway 100 is sliding door system designed for interior and exterior sliding doors up to 100kg per leaf and is ideally suited for use in residential and commercial applications. The system is effortless to operate and extremely durable, due to its nylon bodied hangers complete with four angled nylon outer wheels all housed in a compact aluminium track

Summary of Features See extended features

Options Other systems available to suit other doors sizes and weights. See extended features for further options

Dimensions
Dimensions See extended features

Finishes
Finishes Available n/a

Certification

European Norm No Harmonised European Norm

Product Classification n/a (No Harmonised European Norm)

EC Certificate of Conformity No. n/a (No Harmonised European Norm)

Certifire No. n/a (No Harmonised European Norm)

Declaration of Performance n/a (No Harmonised European Norm)

Other Test Evidence n/a

BIM Assist™

BC(A)R Assist™*

Guarantee **1 Year**

Last Reviewed 06/02/2018

* ROI Only

For the purpose of continual product development, KCC reserves the right to change specifications without notice. Please accept all dimensions as approximate. E&OE. © KCC Group 2020.

Description

Coburn Straightaway sliding door system for doors up to 100kg per leaf



Features

- Top hung sliding system for timber or metal doors up to 100kg
- Suitable for use both internally and externally
- Smooth and quiet operation provided by anodised aluminium track and nylon wheeled hangers
- Tracks can be mounted directly to the soffit or wall mounted using brackets
- Track is self-cleaning due to the angled nylon wheels on the door hanger
- Hangers have vertical adjustment to ensure a perfect fit
- Range of bottom guiding options available to achieve a clear threshold
- Track concealed soft closing option
- Simultaneous opening option available for bi-parting doors
- Telescopic opening options for 2 doors and 3 doors available
- Any number of doors can be used on single or multiple lines of track to cover the width of the opening
- Straightaway 100SS with grade 316 stainless steel components is available for harsh operating environments



Technical Characteristics

- Maximum door weight: 100kg
- Maximum door height: 2500mm
- Door Thickness: 20 – 50mm (minimum door thickness of 30mm when using a channel)
- Track Dimensions: W28mm x H30mm (galvanised steel) & W31mm x H30mm (aluminium)

Trackset 950mm (No Bottom Channel)

- 01218: Trackset for one door up to 950mm

Trackset contains:

- 12318 Track 1800mm x 1
- 01207 Hanger pack x 1
- 01725 Track end piece x 2
- 42371 Floor guide x 1
- 01040 Side fixing brackets x 4
- 11154 Spanner

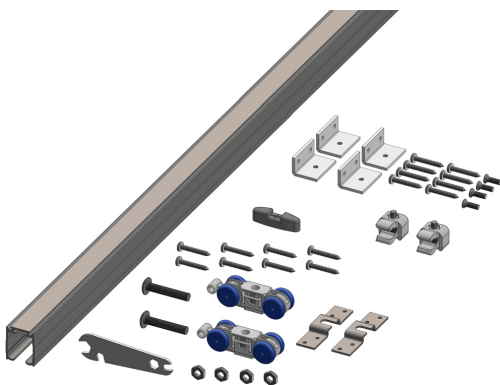

For the purpose of continual product development, KCC reserves the right to change specifications without notice. Please accept all dimensions as approximate. E&OE. © KCC Group 2020.

www.thekccgroup.com

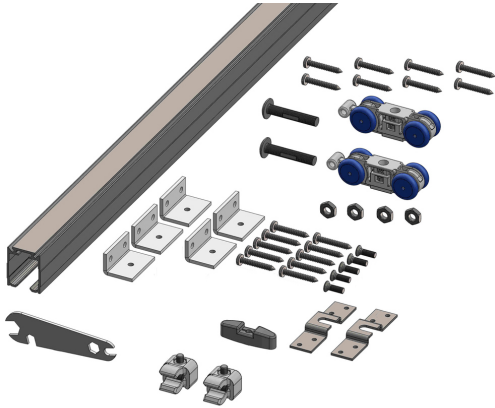

Trackset 1250mm (No Bottom Channel)

- 01224: Trackset for one door up to 1250mm

Trackset contains:

- 12324 Track 2400mm x 1
- 01207 Hanger pack x 1
- 01725 Track end piece x 2
- 42371 Floor guide x 1
- 01005 Side fixing brackets x 5
- 11154 Spanner



Guides

Select your floor guide arrangement

- 03937: Adjustable rattle proof guide - 6mm roller
- 03938: Adjustable rattle proof guide - 13mm roller
- 22392: Floor guide, plastic, (timber doors)
- 44319: Floor guide, pair, (metal doors)



Door Synchroniser

Select from options

- 61401: Simultaneous door synchronising kit (for simultaneous opening and closing of two sliding doors). Combined doors up to 800mm wide
- 61403: Simultaneous door synchronising kit (for simultaneous opening and closing of two sliding doors). Combined doors up to 1200mm wide



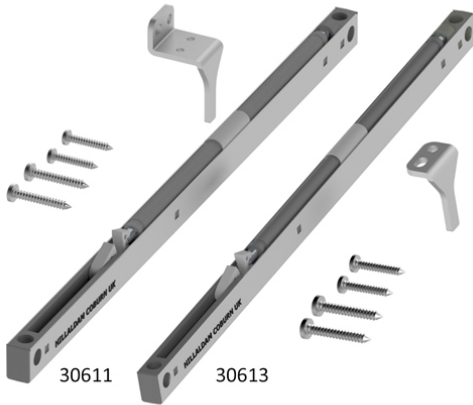

Soft Closer

Select from options

- 30611: Soft closer, single damper, 70kgs (side fix)
- 30613: Soft closer, single damper, 70kgs (soffit fix)

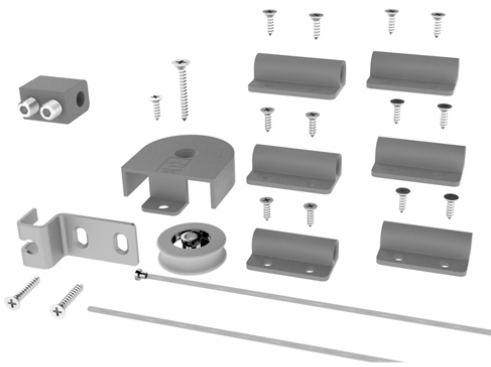

Self Closer

- 30701: Self closer - for doors upto 100kg per leaf



Bottom Channel

Select a bottom channel

- 41215: Anodised Aluminium, suites 03937 or 22392 guide, 1500mm
- 41218: Anodised Aluminium, suites 03937 or 22392 guide, 1800mm
- 41221: Anodised Aluminium, suites 03937 or 22392 guide, 2100mm
- 41224: Anodised Aluminium, suites 03937 or 22392 guide, 2400mm
- 41230: Anodised Aluminium, suites 03937 or 22392 guide, 3000mm
- 43220: Anodised Aluminium, suites 03938 guide, 2000mm
- 43224: Anodised Aluminium, suites 03938 guide, 2400mm
- 43230: Anodised Aluminium, suites 03938 guide, 3000mm
- 43236: Anodised Aluminium, suites 03938 guide, 3600mm
- 43240: Anodised Aluminium, suites 03938 guide, 4000mm
- 44215: Anodised Aluminium, suites 44319 guide, 1500mm
- 44218: Anodised Aluminium, suites 44319 guide, 1800mm
- 44221: Anodised Aluminium, suites 44319 guide, 2100mm
- 44224: Anodised Aluminium, suites 44319 guide, 2400mm
- 44230: Anodised Aluminium, suites 44319 guide, 3000mm
- 44236: Anodised Aluminium, suites 44319 guide, 3600mm

For the purpose of continual product development, KCC reserves the right to change specifications without notice. Please accept all dimensions as approximate. E&OE. © KCC Group 2020.

Description

Coburn Straightaway sliding door system for doors up to 100kg per leaf



Specification Text

GENERAL HARDWARE

- Manufacturer: Coburn
- Product reference: [ITEMS AS SCHEDULE]
- Type: Straightaway 100 Sliding Door System
- Size: See drawings
- Material/ finish: n/a